

SHORT COMMUNICATION

Contributions intended for publication under this heading should be expressly so marked; they should not exceed about 1000 words; they should be forwarded in the usual way to the appropriate Co-editor; they will be published as speedily as possible.

Acta Cryst. (1980). B36, 998–1000

Hydrogen bonds and short intermolecular contacts involving nitroxide groups in crystals. By B. CHION and J. LAJZÉROWICZ-BONNETEAU, *Laboratoire de Spectrométrie Physique, Université Scientifique et Médicale de Grenoble, BP n° 53, 38041 Grenoble CEDEX, France*

(Received 29 May 1979; accepted 2 January 1980)

Abstract

In fifteen structures of molecular compounds of nitroxide free radicals, intermolecular environments of nitroxide groups have been analysed. When there is a possibility of intermolecular hydrogen bonding, it always exists. If not, there are short contacts between the oxygen atom and the methyl or methylene groups. The geometrical features found for these intermolecular contacts are very similar.

The stability of aliphatic nitroxides, and the simplicity and sensitivity of their EPR spectra to environmental perturbations have made them objects of considerable interest and wide application (Rosantsev, 1970; MacConnel, 1968; Berliner, 1976).

Recent studies (Morishima, Ishihara, Tomishina, Inubushi & Yonezawa, 1975; Endo, Knuettel, Morishima, Inubushi & Yonezawa, 1975) on NMR contact shifts have shown that nitroxide radicals can be used in solutions to give information about the structural and electronic characteristics of the solvent molecule perturbed by association with the free radical. These can be hydrogen bonds, charge-transfer interactions or even short intermolecular van der Waals-type contacts (Talberg & Ottersen, 1975).

In order to interpret all these experiments, hypotheses about the geometries of bonds and contacts had to be made (Morishima, Endo & Yonezawa, 1971; Sysoeva, Karmilov & Buchachenko, 1975): π or σ models have been supposed (Fig. 1); INDO calculations have been tried several times (Morishima, Endo & Yonezawa, 1971), but conclusions often differ. On the same topic a theoretical study (Ellinger, Subra, Berthier & Tomasi, 1975) of the electrostatic potential around the NO group in aminoxyl free radicals shows that the best approach for a proton is towards the lone pairs of oxygen.

For several years we have been studying crystallographic structures of nitroxide compounds, mainly the relations between crystal structure and physical properties [EPR (Capiomont, Chion, LajzÉrowicz & Lemaire, 1974), magnetism (Veyret & Blaise, 1973)], as well as phase transformations. We have noticed several characteristics of solid-state structures of nitroxides:

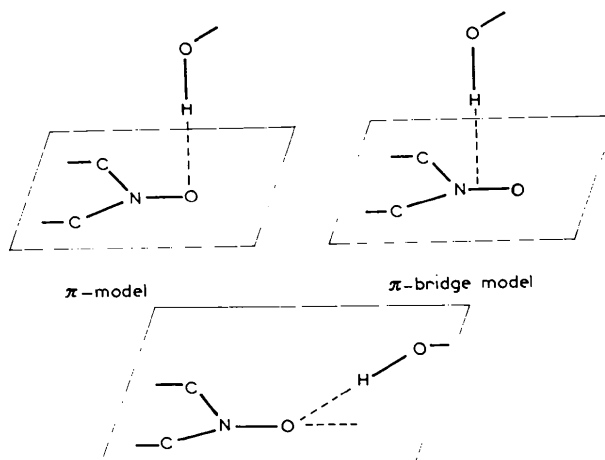

Fig. 1. Different theoretical models.

(1) There is a strong tendency to form hydrogen bonds in which the nitroxide group is involved. When two possibilities are offered, one including the nitroxide group, the other coupling, for example, amide or acid groups, the preference is always for the first.

(2) The geometries of the hydrogen bonds show similar characteristics in all the structures and they are in agreement with the theoretical studies mentioned.

(3) When no hydrogen bonds are possible we have noted the existence of 'short contacts' between the oxygen of the NO group and the carbons of methyl or methylene groups of neighbouring molecules. These contacts have a geometrical disposition similar to that found for hydrogen bonds. [Sometimes there is coupling of the NO groups in the crystal, forming dimers (Capiomont, 1973).]

We thought it interesting to regroup all these results concerning interactions of the NO group with neighbouring molecules in the solid state. This can give indications about the associations in the liquid state.

These results are summarized in Tables 1 and 2 and Figs. 3 and 4. Tables 1 and 2 give the geometrical characteristics of hydrogen bonds and short contacts. The angle Φ is the angle between NO and the CNC plane in the molecule itself

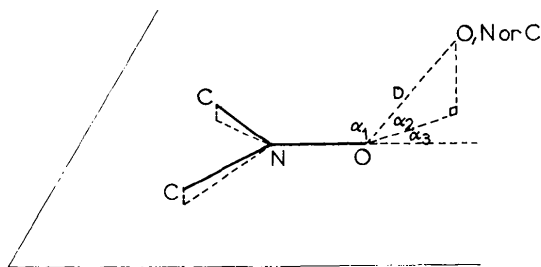

Fig. 2. Characteristics of the geometries of the bonds ($\cos \alpha_1 = -\cos \alpha_2 \cos \alpha_3$).

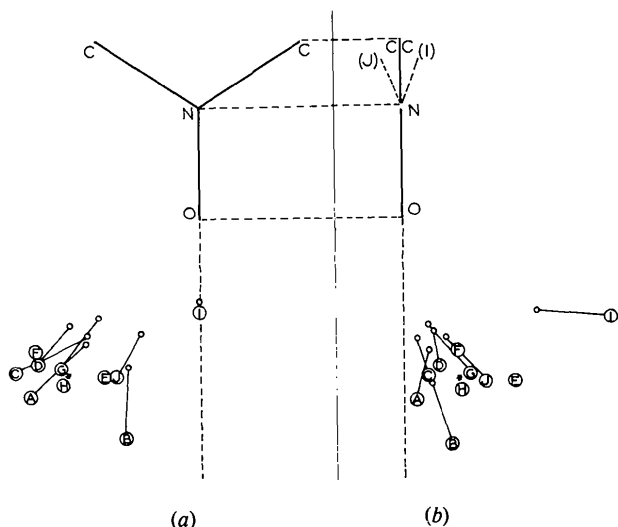

Fig. 3. Hydrogen bonds projected on the plane containing NO and which is (a) parallel to or (b) perpendicular to the C-C bond. O: Oxygen or nitrogen projections, \circ : hydrogen projections.

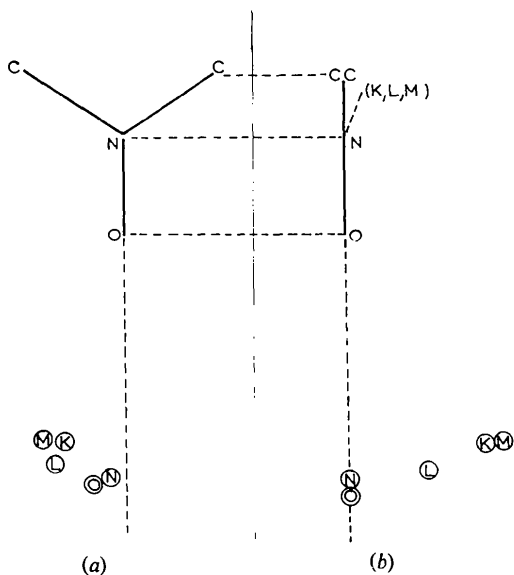
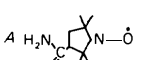
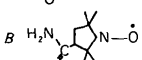
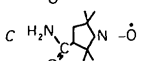
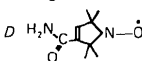
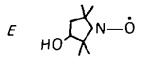
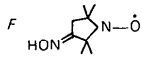
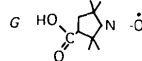
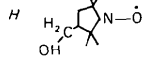
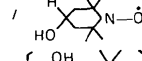
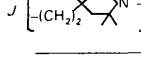

Fig. 4. Short contacts projected on the plane containing NO and which is (a) parallel to or (b) perpendicular to the C-C bond. O: Carbon projections.

Table 1. Hydrogen-bond characteristics (see Fig. 2)

References: (1) Chion & Lajz erowicz (1975); (2) Turley & Boer (1972); (3) Chion, Lajz erowicz, Collet & Jacques (1976); (4) Chion & Thomas (1975); (5) Wetherington, Ament & Moncrieff (1974); (6) Chion & Lajz erowicz (1978); (7) Lajz erowicz (1968); (8) Shibaeva (1974).



	Reference	Φ	D	α_1	α_2	α_3		
A		(1)	1.6	3.10	138.6	1.1	42.0	NO-HN
B		(1)	3.8	3.01	159.5	10.6	17.6	NO-HN
C		(1)	0.9	3.04	130.6	6.2	49.1	NO-HN
D		(2)	0.0	3.03	128.3	8.3	51.2	NO-HN
E		(3)	0.0	2.72	139.7	29.3	28.9	NO-HO
F		(4)	5.7	2.71	131.1	7.0	48.4	NO-HO
G		(5)	3.3	2.70	137.2	15.9	40.0	NO-HO
H		(6)	2.9	2.79	139.9	13.2	38.2	NO-HO
I		(7)	15.8	2.82	124	56.0	0	NO-HO
J		(8)	19.0	2.83	148.9	21.3	23	NO-HO

(it defines the conformation of the $\begin{matrix} C \\ \diagdown \\ C \end{matrix} \text{NO}$ group). The distance and the three angles defining the geometry of the bonding are shown in Fig. 2. Figs. 3 and 4 are projections of the bonds or contacts on the plane that contains NO and is parallel to C-C (Figs. 3a, 4a) and also on the plane passing through NO and perpendicular to the C-C bond (Figs. 3b, 4b). When the hydrogen has been located (in hydrogen-bonding interactions) it is indicated in the figure and the bonding is drawn (compounds A, B, C, D, G, I, J).

For the majority of compounds (except B and I) the geometries of the hydrogen bonds are very similar and we can define a mean geometry, much nearer to the σ model than to the π model, with mean values of 134° for α_1 , 13° for α_2 , and 38° for α_3 . The corresponding mean position (for a distance of 2.8 Å) is noted by an asterisk in Fig. 3. The 'short-contact' bonds are, in general, closer to the NO bond direction. When the $\begin{matrix} C \\ \diagdown \\ C \end{matrix} \text{NO}$ group is not planar the projections of the 'contact' atom and of the carbons of $\begin{matrix} C \\ \diagdown \\ C \end{matrix} \text{NO}$ are on the same side of the NO bond in Fig. 4(b).

Table 2. 'Short-contact' characteristics (see Fig. 2)

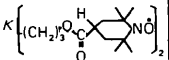
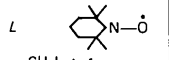
References: (1) Capiomont (1972); (2) Capiomont & Lajz rowicz (1974); (3) Murray-Rust (1974); (4) Moutin, Rassat, Bordeaux & Lajz rowicz (1976); (5) Bordeaux & Lajz rowicz (1974).

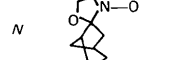
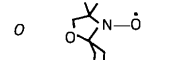
	Reference	Φ	D	α_1	α_2	α_3	
K 	(1)	10.2	3.36	143	34	15	NO-CH ₂
L 	(2)	19	3.37	131	49	0	NO-CH ₂
M 	(3)	17	3.34	139.9	35.4	20.2	NO-CH ₃
N 	(4)	7	3.32	171	9	1	NO-CH ₂
O 	(5)	0	3.22	175	5	0	NO-CH ₂

References

- BERLINER, L. J. (1976). *Spin Labelling and Applications*. London: Academic Press.
- BORDEAUX, D. & LAJZ ROWICZ, J. (1974). *Acta Cryst.* **B30**, 2130-2132.
- CAPMONT, A. (1972). *Acta Cryst.* **B28**, 2298-2301.
- CAPMONT, A. (1973). *Acta Cryst.* **B29**, 1720-1722.
- CAPMONT, A., CHION, B., LAJZ ROWICZ, J. & LEMAIRE, H. (1974). *J. Chem. Phys.* **60**(6), 2530-2535.
- CAPMONT, A. & LAJZ ROWICZ, J. (1974). *Acta Cryst.* **B30**, 2160-2166.

- CHION, B. & LAJZ ROWICZ, J. (1975). *Acta Cryst.* **B31**, 1430-1435.
- CHION, B. & LAJZ ROWICZ, J. (1978). *Cryst. Struct. Commun.* **7**, 395-398.
- CHION, B., LAJZ ROWICZ, J., COLLET, A. & JACQUES, J. (1976). *Acta Cryst.* **B32**, 339-344.
- CHION, B. & THOMAS, M. (1975). *Acta Cryst.* **B31**, 472-473.
- ELLINGER, Y., SUBRA, R., BERTHIER, G. & TOMASI, J. (1975). *J. Phys. Chem.* **79**, 2440-2443.
- ENDO, K., KNUETTEL, B., MORISHIMA, I., INUBUSHI, T. & YONEZAWA, T. (1975). *Chem. Phys. Lett.* **31**(2), 387-391.
- LAJZ ROWICZ, J. (1968). *Acta Cryst.* **B24**, 196-199.
- MACCONNEL, H. M. (1968). *Structural Chemistry and Molecular Biology*, pp. 117-149. San Francisco: Freeman.
- MORISHIMA, I., ENDO, K. & YONEZAWA, T. (1971). *Chem. Phys. Lett.* **9**(2), 143-146.
- MORISHIMA, I., ISHIHARA, K., TOMISHINA, K., INUBUSHI, T. & YONEZAWA, T. (1975). *J. Am. Chem. Soc.* **97**(10), 2749-2756.
- MOUTIN, M., RASSAT, A., BORDEAUX, D. & LAJZ ROWICZ, J. (1976). *J. Mol. Struct.* **31**, 275-282.
- MURRAY-RUST, P. (1974). *Acta Cryst.* **B30**, 1368-1370.
- ROSANTSEV, E. G. (1970). *Free Nitroxyl Radicals*. New York, London: Plenum.
- SHIBAEVA, R. P. (1974). *J. Struct. Chem.* **15**(5), 948-952.
- SYSEVA, N. A., KARMILOV, A. Y. & BUCHACHENKO, A. L. (1975). *Chem. Phys.* **7**, 123-129.
- TALBERG, H. J. & OTTERSEN, T. (1975). *J. Mol. Struct.* **29**, 225-231.
- TURLEY, J. W. & BOER, F. P. (1972). *Acta Cryst.* **B28**, 1641-1644.
- VEYRET, C. & BLAISE, A. (1973). *Mol. Phys.* **25**(4), 873-882.
- WETHERINGTON, J. B., AMENT, S. & MONCRIEFF, J. W. (1974). *Acta Cryst.* **B30**, 568-572.

International Union of Crystallography

Acta Cryst. (1980). **B36**, 1000

Commission on Crystallographic Apparatus

IUCr X-ray Attenuation Project

At the International Union of Crystallography Congress which was held in Warsaw in 1978, the Commission on Crystallographic Apparatus decided that there was a need to evaluate the techniques for the measurement of X-ray attenuation coefficients. A committee was set up to organize the project, and planning for the project is now well advanced.

It is the aim of the organizing committee to encourage the participation in the project of laboratories using a diverse range of techniques of measurement. For example, sources of incident X-ray beams which are to be used range from synchrotron radiation sources to radio-isotope sources. A diverse range of detection systems are also to be used.

All laboratories participating in the project will receive standard specimens from the project organizers and will be required to answer detailed questions about their equipment, techniques of measurement and their analysis of the experimental results. The first specimen will be silicon. Later specimen sets will include germanium, magnesium and pyrolytic graphite.

Any laboratory interested in participating in the project should contact: Dr D. C. Creagh, Chairman, IUCr X-ray Attenuation Project, Physics Department, Royal Military College, Duntroon, ACT 2600, Australia.